



CRYO/02/032  
December, 18, 2002

## Analytical Solution for the Current Distribution in Multistrand Superconducting Cables

L. Bottura<sup>a</sup>, M. Breschi<sup>b</sup>, M. Fabbri<sup>b</sup>

<sup>b</sup> DIE, Department of Electrical Engineering, University of Bologna, Italy

Distribution: Internal

Published: Journal of Applied Physics, **92**(12), 7571-7580, 2002

---

### Summary

*Current distribution in multistrand superconducting cables can be a major concern for stability in superconducting magnets and for field quality in particle accelerator magnets. In this paper we describe multistrand superconducting cables by means of a distributed parameters circuit model. We derive a system of partial differential equations governing current distribution in the cable and we give the analytical solution of the general system. We then specialize the general solution to the particular case of uniform cable properties. In the particular case of a two-strand cable, we show that the analytical solution presented here is identical to the one already available in the literature. For a cable made of  $N$  equal strands we give a closed form solution that to our knowledge was never presented before. We finally validate the analytical solution by comparison to numerical results in the case of a step-like spatial distribution of the magnetic field over a short Rutherford cable, both in transient and steady state conditions.*

---

### 1. Introduction

Conductors designed and built for large-scale superconducting AC applications and for DC magnets are cables made by twisting strands or tapes in concentric layers or, alternatively, braids made by interlacing strands. Strands based on low-temperature superconductors consist of thousands of superconducting filaments with typical diameters in the range from 5 to 50 microns, extruded in a normal metal matrix. Tapes of high-temperature superconductors are flat ribbons containing twisted or untwisted filaments with typical size in the 10 to 100 microns range. For most power applications the strands and tapes have a characteristic size much smaller than the cable size, and thus their internal structure can be ignored.

The strands and tapes are twisted or transposed in order to reduce the induced circulation currents and the resulting AC loss generated by time dependent external magnetic fields. The transposition is generally incomplete due to the following two main reasons:

- the single strands and sub-cables in a twisted cable are still coupled with the self field generated by the transport current;
- often the strands do not link the same flux, as for example in an ideally transposed cable subjected to a field with longitudinal gradient, or in the case of manufacturing deviations from the ideal, perfectly transposed geometry. An example of particular relevance is superconducting dipoles for particle accelerators, where the cable bending over the magnet ends causes a strong longitudinal field gradient.

In order to study current distribution phenomena in multistage superconducting cables, we have developed in the past years a distributed parameters model that allows to calculate current distribution in very long cables used in magnets due to a substantial decrease of the number of the unknowns of the problem [1-6]. The model is a special case of a multi-conductor transmission line for which standard theory is available in the field of electrical engineering. As we will show in this paper, another remarkable advantage of this formulation as compared to the lumped parameters network model is the possibility to find an analytical solution of the governing equations.

Several authors have undertaken analytical treatment of current distribution and redistribution under much simplified conditions (e.g. two-strand cables) [7-12]. In particular, Turck [7] analyzed current sharing between two non-insulated coupled superconducting wires, with and without superficial oxides. He showed that an equilibrium current sharing imposed at the cable ends propagates axially along the composite to produce current redistribution. This propagation is achieved with a magnetic diffusivity dependent on the interstrand contact resistance and on the mutual coupling between the strands. In [8, 9] the analytical solution was also applied to the analysis of current redistribution in the presence of faulty wires or short circuits between strands.

Ries [10] has used an analytic approximation for the current sharing among quenching strands either insulated or soldered, in a study aimed at determining the stability of a multi-strand cable. The analytical approximation was used to estimate the power dissipated during the thermal transient and the characteristic time necessary for current distribution.

More recently Krempasky and Schmidt [11] have given the analytical solution of the equation of current diffusion in a two-strand cable and applied it to the study of long range “supercurrents” induced by longitudinal variations of the time derivative of the magnetic field applied to the cable. The evaluation of the strand currents in the presence of a generic current cycle was obtained by considering two different analytical solutions of the equation of current diffusion in the presence of field ramps (forced diffusion), and during constant field phases (free diffusion). Due to the linearity of the model, the final currents in the two strands were evaluated by a superposition of the effects of different ramps and constant field phases.

Mitchell [12] used an approximate analytical model of a two-strand cable derived using the same model as the one described in [11] to study the effect of current redistribution from a normal zone on the stability margin of a cable. The approximate model assumes that the strands portion where the current redistribution takes place is in superconducting state.

In this work we extend the analytical solution of the equations of current diffusion to cables made of a generic number of strands and compare it to numerical simulations in both transient conditions and steady state regimes. The solution is given for any multi-strand superconducting cable that satisfies specific symmetry and periodicity conditions on the matrices of mutual inductances and interstrand resistances. These conditions are generally met in cables with high degree of spatial symmetry, such as Rutherford cables or power transmission cables. As we will discuss later on, symmetry and periodicity conditions are met *on average* also in bundled cables such as those used in Cable-in-Conduit Conductors (CICCs), both at the level of the single strands, as well as at the level of strand bundles taken as “superstrands” with homogenized properties.

Our general solution reduces to the solution given in [11] when a two-strand cable exposed to a localized external flux change is considered. As we will show, it is however possible to derive directly an analytical solution also in the case of cables made of equal strands, thus enlarging significantly the possibility of fast scoping and parametric studies. A comparison to numerical results obtained in the case of a short cable subjected to a variable field with a step distribution in space is used to validate the analytical solution presented.

## 2. Model Description

The model for the current distribution in a superconducting cable is based on the distributed parameters circuit description discussed in detail in [3-6]. The model assumes that each strand carries a current uniformly distributed in its cross section, and thus neglects the coupling currents that flow inside each strand among the twisted superconducting filaments.

The key postulate in the model is the hypothesis that the current can flow continuously from each strand to all the other strands through distributed contacts. Similarly the longitudinal voltages, e.g. induced by a time dependent external magnetic field  $dB/dt$ , are also distributed along the cable length. A schematic representation of the equivalent distributed parameters model of the cable (for three strands) is shown in Fig. 1.

The  $N$  strands have initial currents  $i_i$  and voltages  $V_i$  at the coordinate  $x$  (with  $i = 1, N$ ). Over an elemental length  $dx$  the currents change by  $di_i$  because of current transfer across the interstrand contact resistances  $R_{i,j} = 1/(g_{i,j} dx)$ , where  $g_{i,j}$  is the interstrand conductance per unit length between the  $i$ -th and  $j$ -th strand. The voltages drop by  $dV_i$  due to the parallel resistance, inductive voltages, and the voltage source  $v_i^{ext}$ .

Applying the Kirchhoff's current and voltage laws to the distributed parameters circuit, we obtain the following systems of partial differential equations:

$$\frac{\partial \mathbf{v}}{\partial x} = -\mathbf{r}\mathbf{i} - \mathbf{l} \frac{\partial \mathbf{i}}{\partial t} + \mathbf{v}^{ext} \quad (1)$$

$$\frac{\partial \mathbf{i}}{\partial x} = \mathbf{g} \mathbf{v} \quad (2).$$

The vectors  $\mathbf{i}$  and  $\mathbf{v}$  contain the  $N$  strand currents and voltages respectively, and  $\mathbf{l}$ ,  $\mathbf{r}$ ,  $\mathbf{g}$ , are the system inductance, resistance and conductance matrices of dimension  $N \times N$ . The elements of  $\mathbf{l}$  are the inductance coefficients among strands  $l_{i,j}$ , defined on a unit length basis. The matrix  $\mathbf{r}$  is diagonal, and the elements  $r_{i,i}$  are the longitudinal strand resistances per unit of strand length. The system conductance matrix is defined as follows:

$$\mathbf{g} = \begin{bmatrix} -\sum_{\substack{k=2 \\ k \neq 1}}^N g_{1,k} & g_{1,2} & \cdots & g_{1,N} \\ g_{2,1} & -\sum_{\substack{k=1 \\ k \neq 2}}^N g_{2,k} & \cdots & g_{2,N} \\ \vdots & & & \\ g_{N,1} & g_{N,2} & \cdots & -\sum_{\substack{k=1 \\ k \neq N}}^N g_{N,k} \end{bmatrix} \quad (3)$$

We come to a single system of partial differential equations for the currents in the strands taking the space derivative of equation (2), and assuming that the interstrand conductances are uniform along the cable axis:

$$\mathbf{g}\mathbf{l} \frac{\partial \mathbf{i}}{\partial t} + \frac{\partial^2 \mathbf{i}}{\partial x^2} + \mathbf{g}\mathbf{r}\mathbf{i} - \mathbf{g}\mathbf{v}^{ext} = 0 \quad (4).$$

Equation (4) is a system of parabolic differential equations that describes the current diffusion along the cable generated by field or current ramps.

The system of equations (4) must be complemented by an appropriate choice of the boundary and initial conditions. Different choices of boundary conditions are possible for the study of current distribution in multistrand cables [2, 3], implying different analytical solutions. For our study we take a generic initial current distribution within the cable, but we make the assumption of uniform current distribution among the different cable strands at the cable ends:

$$\mathbf{i}(x, t = 0) = \mathbf{i}^{(0)}(x)$$

$$i_h(x = 0, t) = i_h(x = L, t) = \frac{i_{op}(t)}{N} \quad \text{with } h = 1, \dots, N \quad (5)$$

where  $i_{op}$  is the total operation current flowing in the cable. The particular choice made in Equation (5) was used because it was directly investigated experimentally [13].

### 3. Main Assumptions and Analytical Solution

The model described in Section 2 is still too general to allow a complete analytical treatment. To proceed with the solution we consider the simpler case in which all the strands have the same longitudinal resistance  $r$  (and  $r = 0$  if the strands are in the superconducting state). In this case the matrix  $\mathbf{r}$  can be also written as  $r \mathbf{I}$ , where  $\mathbf{I}$  is the unit matrix. To find the analytical solution of Eq. (4) we need the eigenvalues and eigenvectors of matrices  $\mathbf{g}$  and  $\mathbf{I}$ . These can be obtained analytically when the matrices of mutual inductances  $\mathbf{I}$  and transverse conductances  $\mathbf{g}$  are symmetric and circulant [14], i. e.:

- a)  $a_{i,j} = a_{j,i}$ , with  $i, j = 1, \dots, N$
- b)  $a_{i,1} = a_{i-1,N}$ ,  $a_{i,j} = a_{i-1,j-1}$ , with  $i, j = 2, \dots, N$

where  $a_{ij}$  is a generic element of either matrix  $\mathbf{g}$  or  $\mathbf{I}$ . The symmetry implied by hypothesis a) is obvious for both matrices and any cable geometry because of the physical symmetry of the coefficients of mutual inductances and contact conductances. The circularity condition b) corresponds physically to the fact that the matrices must be invariant for a longitudinal translation of the cable by a length characteristic of the cable periodicity. This condition is generally met in several practical cases either exactly or on average.

In order to expand on the physical implications of hypothesis b) we take as an example an infinite, straight length of Rutherford cable with  $N$  strands. In this case the self inductance of the strands, i.e. the diagonal terms  $l_{i,i}$  of the inductance matrix  $\mathbf{I}$ , are all identical as each strand follows the same path along the cable length apart for a rigid translation by an integer multiple of  $L_p/N$ , where  $L_p$  is the cable twist pitch, which does not affect the value of the inductance. In addition if we take any couple of strands  $i$  and  $j$  these are geometrically not distinguishable from the couple of strands  $i - k$  and  $j - k$  apart for a rigid longitudinal translation by  $-k L_p/N$ . This translation does not affect inductances and we can therefore write that  $l_{ij} = l_{i-k,j-k}$ . The two properties above guarantee that in the case of a Rutherford cable the inductance matrix is circulant, as also verified in [6] through 3-D numerical calculations.

We now turn our attention to the conductance matrix  $\mathbf{g}$ . In a Rutherford cable two types of different contacts can be identified. Adjacent strands have continuous contacts along the cable length, while non adjacent strands only have two contacts per twist pitch. If we suppose cross contact conductances to be uniform both along the cable length and across the cable width, we have only two possible different values for the interstrand contact conductances:  $g_a$  for adjacent strands, and  $g_c$  for non adjacent strands. The terms

appearing in the conductance matrix are then  $g_{i,i} = 0$  by definition,  $g_{i,i+1} = g_{i,i-1} = g_a$  for adjacent strands, and  $g_{i,j} = g_c$  for all other terms. Once again the high degree of spatial symmetry of the cable guarantees that also the conductance matrix  $\mathbf{g}$  satisfies the circularity condition b).

The same reasoning and similar arguments can be used to show that other single-stage common cable configurations such as strand triplets or quadruplets also result in circulant conductance and inductance matrices. For multi-stage cables the conductance and inductance matrices can have a complex structure that is no longer exactly circulant. In general, however, cables are designed so that they are fully transposed with respect to external field changes. This implies that for a length longer than the transposition length a strand in the cable cannot be distinguished from any other strand, and the properties of all strands are the same. As a result the conductance and inductance matrices are expected to be circulant *on average*.

Under the hypotheses discussed above, the analytical solution of Eq. (4) is the following:

$$\mathbf{i}(x, t) = \frac{i_{op}(t)}{\sqrt{N}} \mathbf{b}_0 + \frac{2}{L} \int_0^L d\xi \mathbf{K}^{(0)}(x, \xi, t) \mathbf{i}^{(0)}(\xi) + \frac{2}{L} \int_0^L d\xi \int_0^t d\tau \mathbf{K}(x, \xi, t - \tau) \mathbf{v}^{ext}(\xi, \tau) \quad (6)$$

where  $L$  is the cable length, while the vector  $\mathbf{b}_0$  and the integration kernels  $\mathbf{K}^{(0)}$  and  $\mathbf{K}$  are defined in Appendices A and B. The first term in the solution Eq. (6) corresponds to the uniform current distribution, while the second and the third term give the current imbalance due respectively to the initial conditions  $\mathbf{i}^{(0)}(x)$  and to the external longitudinal voltages  $\mathbf{v}^{ext}(x, t)$ . The solution Eq. (6) is very general, and can be applied to any current cycle as well as any space and time dependent external field applied to the cable.

In the case that the transient starts from zero cable current  $i_{op}(0) = 0$ , and if  $\mathbf{v}^{ext}$  is independent of time, as is the case for ramps of current and field with constant rate, the solution Eq. (6) can be simplified as follows:

$$\mathbf{i}(x, t) = \frac{i_{op}(t)}{\sqrt{N}} \mathbf{b}_0 + \frac{2}{L} \int_0^L d\xi \mathbf{K}^*(x, \xi, t) \mathbf{v}^{ext}(\xi) \quad (7)$$

where the integration kernel  $\mathbf{K}^*$  is defined in Appendix B. In cases of very long transients, and with the boundary conditions assumed in (5), the strand currents reach a steady-state regime whose pattern depends only on the external voltage and on the longitudinal resistance per unit length. In order to calculate the regime currents we can write Eq. (10) in the following form:

$$\mathbf{i}(x, \infty) = \frac{i_{op}(\infty)}{\sqrt{N}} \mathbf{b}_0 + \frac{2}{L} \int_0^L d\xi \mathbf{K}^*(x, \xi, \infty) \mathbf{v}^{ext}(\xi) \quad (8)$$

where  $i_{op}(\infty)$  is the regime value of the transport current, and the regime value of the kernel  $\mathbf{K}^*(x, \mathbf{x}, \infty)$  can be obtained directly from the definitions reported in Appendix B.

Equation (7) can be finally solved specializing the space dependence of the external voltage  $\mathbf{v}^{ext}$ . The simplest case that can be considered is when the external voltage is piecewise constant along the cable length, defined by the series of vectors  $\mathbf{v}^{ext,m}$  relative to the  $M$  space intervals  $[x^m, x^{m+1}]$ , with  $m = 1, \dots, M$ . In this case the integration of the kernel  $\mathbf{K}^*$  can be performed analytically, and the resulting current distribution is given by the following expression:

$$\mathbf{i}(x, t) = \frac{i_{op}(t)}{\sqrt{N}} \mathbf{b}_0 + 2 \sum_{m=1}^M \mathbf{K}^{**}(x, t; x^m, x^{m+1}) \mathbf{v}^{ext,m} \quad (9).$$

where the matrix  $\mathbf{K}^{**}$  is given in closed form in Appendix B. Equation (9) provides the complete solution sought for the current distribution problem represented by the system of Eqs. (4) in the case of time invariant, piecewise constant external voltage.

#### 4. Cables Consisting of Equal Strands under Localized Voltage Excitation

In the case of cables consisting of equal strands that cannot be distinguished, it is possible to simplify to a large extent the solution given in the previous section. We consider in particular cables with uniform longitudinal conductance  $g_{i,j} = g$ . We assume further that the self inductances  $l_{i,i}$  and mutual inductances  $l_{i,j}$  are the same for all the strands and strand couples and we indicate them with  $l$  and  $m$  respectively. The symmetry and circularity conditions can be verified easily. The cable is subjected to a longitudinal voltage with amplitude  $\mathbf{v}^{ext}$  lasting for a time  $t_1$  and localized over a short length  $\mathbf{d}$  placed in the middle of the cable, as would be generated, for instance, by a change of magnetic flux linked to a cable transposition error. The cable has length  $L$ , no longitudinal resistance and zero transport current. The following sections give the analytical solutions for a two-strand cable as well as a cable of  $N$  strands.

##### 4.1 Two-strand cable

In the simple case of a two-strand cable it is possible to show that the general solution Eq. (6) can be reduced to the simple expressions found in [11]. The details on how to reduce the general solution to the case of two strands can be found in Appendix C. In accordance with [11] we define the parameters  $w = (L - \delta)/2$ ,  $\mathbf{a} = \pi w/L$ . The current in the first strand is given by:

$$i_1(x, t) = \frac{4}{\mathbf{pa}} I_1 \sum_{\substack{n=1 \\ n \text{ odd}}}^{\infty} \frac{1}{n^2} (1 - e^{-t/t_n}) \sin\left(\frac{n\mathbf{a}x}{w}\right) \sin(n\mathbf{a}) \quad (10)$$

where the regime current for the case of a two-strand cable is given by

$$I_1 = \frac{wg\mathbf{d}}{2} (v_1^{ext} - v_2^{ext}) \quad (11)$$

and the time constant  $\mathbf{t}$  is defined as follows:

$$\mathbf{t} = 2g(l-m) \left( \frac{L}{\mathbf{p}} \right)^2 \quad (12)$$

The current in the second strand  $i_2$  is identical in module to  $i_1$  but has opposite sign. In the form of Eq. (10) the solution found is identical to Eq. (29) of [11] for the so-called *supercurrents*. If the external voltage source disappears at time  $t_1$ , the supercurrents start a free decay from the value reached at  $t_1$ . Each component under the sum in (10) decays with its own time constant  $\mathbf{t}_n$  (see [11] and Appendix C):

$$i_1(x,t) = \frac{4}{\mathbf{pa}} I_1 \sum_{\substack{n=1 \\ n \text{ odd}}}^{\infty} \frac{1}{n^2} (1 - e^{-t/t_n}) \sin\left(\frac{n\mathbf{a}x}{w}\right) \sin(n\mathbf{a}) e^{-(t-t_1)/t_n} \quad (13).$$

In Fig. 2 we show the evolution of the current in the first strand of a two-strand cable of length  $L = 2.3$  m caused by a voltage source in the first strand  $v_1^{ext}$  of  $10 \mu\text{V/m}$  localized in the center of the cable with  $\mathbf{d} = 0.1$  m and acting for a time  $t_1$  equal to 10 s. No voltage was applied in the second strand. Because of symmetry, only one half of the cable length is plotted in Fig. 2. The cable self and mutual inductances are  $l = 0.5 \mu\text{H/m}$  and  $m = 0.25 \mu\text{H/m}$ , while the conductance is  $g = 7.463 \text{ MS/m}$ , so that the time constant  $\mathbf{t}$  is 2 s. The current rises under the voltage difference, approaching steady-state conditions for times much longer than the time constant. As soon as the voltage source is removed the current diffuses and decays. Note finally that once normalized by the regime current, the results of Fig. 2 would be the same for any combination of inductances and conductance leading to the same time constant.

#### 4.2 $N$ -strand cable

The results found for the two-strand cables can be generalized to the case of an  $N$  strand cable using the definitions given in Appendices A and B and the methodology demonstrated in Appendix C for the case of two strands. For this case we only give the final result for the current in the  $i$ -th strand:

$$i_i(x,t) = \frac{4}{\mathbf{pa}} I_i \sum_{\substack{n=1 \\ n \text{ odd}}}^{\infty} \frac{1}{n^2} (1 - e^{-t/t_n}) \sin\left(\frac{n\mathbf{a}x}{w}\right) \sin(n\mathbf{a}) \quad (14)$$

where the regime current for strand  $i$  is defined as follows:



$$I_i = \frac{wg\mathbf{d}}{2} \sum_{\substack{j=1 \\ j \neq i}}^N (v_i^{ext} - v_j^{ext}) \quad (15).$$

Equation (15) has a clear resemblance to the definition of the regime current for two strands, Eq. (11). For the case of  $N$  strands however the contributions of the  $(N-1)$  couples of strands in the cable add-up to the total current flowing in one strand. The time constant  $\mathbf{t}$  is given by:

$$\mathbf{t} = Ng(l-m) \left( \frac{L}{\mathbf{p}} \right)^2 \quad (16)$$

which is a factor  $N/2$  larger than for a two-strand cable. All other quantities are defined as for the case of two strands. As in the two-strand cable, if at time  $t_1$  the external voltage source disappears the induced currents start a free decay given by:

$$i_i(x, t) = \frac{4}{\mathbf{p}\mathbf{a}} I_i \sum_{\substack{n=1 \\ n \text{ odd}}}^{\infty} \frac{1}{n^2} (1 - e^{-t/t_n}) \sin \left( \frac{n\mathbf{a}x}{w} \right) \sin(n\mathbf{a}) e^{-(t-t_1)/t_n} \quad (17)$$

We have taken the same parameter values used in the example shown in Fig. 2 to study the solution obtained for the  $N$ -strand cable as a function of the number of strands. In particular we have considered the case when a single strand is subjected to an external voltage source,  $v_1^{ext}$ , with all other voltages equal to zero. This case allows a direct comparison of results, and any general case can be obtained as a linear combination of the single strand excitation. The solution obtained for the evolution of the current in the centre of the cable is shown in Fig. 3 for values of  $N = 2, 3, 4$  and  $5$ . In accordance with Eq. (15), the induced current in the first strand for the general case has a total regime value that is  $(N-1)$  times larger than in the two-strand case, and the distribution evolves with a time constant that is  $N/2$  times longer. Note however that if we normalise the current in the first strand to its regime value and we consider the current distribution at the same normalised time  $t/\mathbf{t}$ , the solutions for the first strand is independent of  $N$  and has the same profile plotted in Fig. 2. The currents in all other strands are negative and equal in magnitude, as can be seen writing Eq. (15) explicitly for the case considered.

## 5. Comparison to numerical simulations

For large number of strands, and for complex geometries, the intricacies of the resulting equations make the analytical solution difficult to manage. Therefore to validate the complete analytic solution we have compared the analytical result given by Eq. (6) to the transient and steady state numerical solution of the current diffusion Eq. (4) in the case of a 16-strand Rutherford cable subject to a time varying magnetic field. For this test we have taken the same conditions considered in [15]. We have simulated a length  $L$  of 3.5 m of cable with a twist pitch  $L_p$  equal to 100 mm. The cross contact conductances are taken equal to 20 MS/m for non-adjacent strands and to 2 MS/m for adjacent strands. We

have considered the cable as exposed to a time-dependent magnetic field perpendicular to its broad face. The time derivative of the field is equal to 0 for  $x < L/2$ , while it is taken equal to 0.01 T/s for  $x > L/2$  (see Fig. 4). This leads to a position-dependent voltage  $\mathbf{v}^{\text{ext}}$ . As in [15], the strands have a constant and uniform longitudinal effective strand resistance  $r$  per unit length. We have computed the resulting current, also called “Boundary Induced Coupling Currents” (BICCs) in [15], during their generation and development for a value  $r = 1.54 \cdot 10^{-8} \Omega/\text{m}$ .

The comparison of transient numerical simulation and analytical solution is reported in Figs. 5 and 6. Figure 5 shows the evolution of the current in the center of the cable (i.e.  $x=1.75 \text{ m}$ ) for two strands arbitrarily selected. Figure 6 shows the steady state reached after a sufficiently long time in the same strands. Numerical and analytical values of the strand currents agree as expected. Because of the presence of a space-dependent source term  $\mathbf{v}^{\text{ext}}$ , we have performed the integral on the right hand side of Eq. (6) numerically, with an adaptive gaussian integration. In practical cases the time required for the integration of Eq. (6) can be large, especially when the vector  $\mathbf{v}^{\text{ext}}$  is strongly dependent on position. This is typical in cables with incomplete transposition, where the external voltage has a periodic oscillation in space with period equal to the cable twist pitch. The presence of the oscillation in space causes slow convergence of the numerical integration. As already discussed, a remarkable reduction of calculation time, without significant loss of precision, can be obtained performing the integral in Eq. (6) analytically, assuming the external voltages to be piecewise constant along the cable and summing up all the contributions as in Eq. (9).

## Conclusions

We have presented and discussed an analytical approach to the study of current distribution in multi-strand superconducting cables. Current diffusion among cable strands has been described by a system of parabolic partial differential equations. The system has been solved analytically in special but relevant cases that correspond either exactly or on average to typical multi-strand cables. The correctness of the analytical solution was demonstrated by comparison to published results and to numerical solutions of the original system of partial differential equations in transient and steady state.

The analytical solution found has by nature an involved structure that in practical cases of large cables with position-dependent voltage sources still requires numerical calculation of integral kernels involving the evaluation of infinite series. As a result the calculation time can become large, so that the method described here is not practical for large-scale analyses. In this respect the analytical solution that we have presented here has an interest for use only in special cases, e.g. as a benchmark for numerical codes.

The main advantage of the analytical approach is that it can be used to obtain closed-form solutions in simple cases such as an ideal cable made of few strands. Indeed we have shown that the expression found in the literature for current diffusion in a two-strand cable can be obtained as a special case of our solution. In addition we have used the fact that our solution is more general in its formulation to extend the known expressions to

more complicated geometries, such as a triplet and quadruplets of strands. The analytical solution in this case provides insight in the behaviors and thus gives the possibility to explore scaling when extrapolating to large number of strands.

## References

- [1] L. Bottura, "Modeling stability in superconducting cables", *Physica C*, **310**, pp. 310-316, 1998.
- [2] L. Bottura, M. Breschi, F. Negrini, P.L. Ribani, "Electromagnetic analysis of current distribution in superconducting cables", Special Issue of the Institute of Physics, Conference Series, **167**, pp. 1191-1194, Bristol, 2000.
- [3] A. Akhmetov, L. Bottura, M. Breschi, P. L. Ribani, "A Theoretical Analysis of Current Imbalance in Flat Two Layer Superconducting Cables", *Cryogenics*, **40**, pp. 627-635, 2000.
- [4] L. Bottura, C. Rosso, M. Breschi, "A General Model for Thermal, Hydraulic and Electric Analysis of Superconducting Cables", *Cryogenics*, **40**, pp. 617-626, 2000.
- [5] A. Akhmetov, L. Bottura, M. Breschi, "A Continuum Model for Current Distribution in Rutherford Cables", *IEEE Trans. Appl. Sup.*, **11**, pp. 2138-2141, 2001.
- [6] M. Breschi, "Current distribution in multistrand superconducting cables", Ph.D. Thesis, University of Bologna, Bologna, Italy, 2001.
- [7] B. Turck, "Influence of a transverse conductance on current sharing in a two-layer superconducting cable", *Cryogenics*, **24**, pp. 448-454, August 1974.
- [8] R.I. Schermer, B.P. Turck, "Current sharing between insulated strands in a superconducting cable", *Adv. Cryo. Eng.*, **26**, 599-607, 1980
- [9] D. Faivre, B. Turck, "Current sharing in an insulated multistrand cable in transient and steady state current conditions", *IEEE Trans. Mag.*, **17**, 1, 1048-1051, 1981
- [10] G. Ries, "Stability in superconducting multistrand cables", *Cryogenics*, **20**, pp. 513-519, 1980
- [11] L. Krempasky, C. Schmidt, "Theory of "supercurrents" and their influence on field quality and stability of superconducting magnets", *Jour. Appl. Phys.*, **78** (9), pp. 5800-5810, 1995.
- [12] N. Mitchell, "Analysis of non-uniform current distribution effects in multistage cable-in-conduit conductors", *Cryogenics*, **39**, pp. 539-556, 1999.
- [13] L. Krempasky, C. Schmidt, "Experimental verification of 'supercurrents' in superconducting cables exposed to AC fields", *Cryogenics*, **39**, pp. 23-33, 1999.
- [14] I.S. Gradshteyn, I.M. Ryzhik, *Tables of Integrals, Series, and Products*, Academic Press, London, 1980.
- [15] A. P. Verweij, "Electrodynamics of Superconducting cables in Accelerator Magnets", Ph.D. Thesis, University of Twente, Enschede, Netherlands, 1995.
- [16] M. Breschi, M. Fabbri, "Analytical Solutions for the current distribution in a Rutherford cable with N strands", internal report, DIE Bologna, 2001.

## Appendix A. Eigenvalues and Eigenvectors of the Inductance and Conductance Matrices

Due to complexity of the mathematical treatment, in this Appendix we report the definitions necessary to calculate the eigenvectors and eigenvalues used in the analytical solutions reported in the previous sections. For a detailed derivation of the results reported in this appendix we refer to [16]. We distinguish the case of an odd and even number of strands  $N$ . We start defining an integer  $p$  given by:

$N$ even	$N$ odd
$p = \frac{N}{2}$	$p = \frac{N-1}{2}$

Given the square  $N \times N$ , circulant, symmetric and positive-definite matrix  $\mathbf{I}$  it can be shown [14] that the  $N$  eigenvalues of  $\mathbf{I}$  are positive and are given by:

$N$ even	$N$ odd
$\mathbf{I}_k = l_{11} + 2 \sum_{s=2}^p l_{1,s} \cos \frac{(s-1)k\mathbf{p}}{p} + l_{1,p+1} (-1)^k$ with $k = -(p-1), \dots, p$	$\lambda_k = l_{11} + 2 \sum_{s=2}^{p+1} l_{1,s} \cos \frac{2(s-1)k\pi}{2p+1}$ with $k = -p, \dots, p$

Moreover, given the square  $N \times N$ , circulant and symmetric  $\mathbf{g}$  such that  $g_{11} = -\sum_{\substack{k=1 \\ k \neq 1}}^N g_{1k}$  the

$N$  eigenvalues of  $\mathbf{g}$  are all negative (except for the lowest eigenvalue  $\gamma_0$  which is null) and given by:

$N$ even	$N$ odd
$\mathbf{g}_k = -2 \sum_{s=2}^p g_{1,s} \left[ 1 - \cos \left( \frac{(s-1)kp}{p} \right) \right] - g_{1,p+1}$ with $k = -(p-1), \dots, p$	$\mathbf{g}_k = -2 \sum_{s=2}^{p+1} g_{1,s} \left[ 1 - \cos \left( \frac{2(s-1)kp}{2p+1} \right) \right]$ with $k = -p, \dots, p$

The orthonormal spectral basis  $\mathbf{b}$  consists of  $N$  vectors, each vector having  $N$  components defined as follows:

$N$ even	$N$ odd
$\mathbf{b}_{-q}^T = \left\{ 0, \sqrt{\frac{2}{N}} \sin \frac{2q\mathbf{p}}{N}, \dots, \sqrt{\frac{2}{N}} \sin \left( (2p-1) \frac{2q\mathbf{p}}{N} \right) \right\}$	$\mathbf{b}_{-q}^T = \left\{ 0, \sqrt{\frac{2}{N}} \sin \frac{2q\mathbf{p}}{N}, \dots, \sqrt{\frac{2}{N}} \sin \left( 2p \frac{2q\mathbf{p}}{N} \right) \right\}$
$\mathbf{b}_0^T = \left\{ \frac{1}{\sqrt{N}}, \frac{1}{\sqrt{N}}, \dots, \frac{1}{\sqrt{N}}, \frac{1}{\sqrt{N}} \right\}$	$\mathbf{b}_0^T = \left\{ \frac{1}{\sqrt{N}}, \frac{1}{\sqrt{N}}, \dots, \frac{1}{\sqrt{N}}, \frac{1}{\sqrt{N}} \right\}$
$\mathbf{b}_q^T = \left\{ \sqrt{\frac{2}{N}}, \sqrt{\frac{2}{N}} \cos \frac{2q\mathbf{p}}{N}, \dots, \sqrt{\frac{2}{N}} \cos \left( (2p-1) \frac{2q\mathbf{p}}{N} \right) \right\}$	$\mathbf{b}_q^T = \left\{ \sqrt{\frac{2}{N}}, \sqrt{\frac{2}{N}} \cos \frac{2q\mathbf{p}}{N}, \dots, \sqrt{\frac{2}{N}} \cos \left( 2p \frac{2q\mathbf{p}}{N} \right) \right\}$
$\mathbf{b}_p^T = \left\{ \frac{1}{\sqrt{N}}, \frac{-1}{\sqrt{N}}, \dots, \frac{1}{\sqrt{N}}, \frac{-1}{\sqrt{N}} \right\}$ with $q = 1, \dots, p-1$	 with $q = 1, \dots, p$

## Appendix B. Integration Kernels

The integration kernels used in Eq. (6) are defined as follows:

$$\mathbf{K}^{(0)}(x, \xi, t) = \sum_{\substack{k=-(p-1) \\ k \neq 0}}^p \Gamma_k(x, \xi, t) \mathbf{b}_k \mathbf{b}_k^T \quad (\text{B.1})$$

$$\mathbf{K}(x, \xi, t) = \sum_{\substack{k=-(p-1) \\ k \neq 0}}^p \Gamma_k(x, \xi, t) \frac{\mathbf{b}_k \mathbf{b}_k^T}{\lambda_k} \quad (\text{B.2})$$

where:

$$\Gamma_k(x, \xi; t) = \sum_{n=1}^{\infty} e^{\frac{-t}{\lambda_k} \left[ r - \frac{1}{\gamma_k} \left( \frac{n\pi}{L} \right)^2 \right]} \sin\left(\frac{n\pi x}{L}\right) \sin\left(\frac{n\pi \xi}{L}\right) \quad (\text{B.3})$$

If the current distribution is initially uniform, so that all components in the vector  $\mathbf{i}^{(0)}(\mathbf{x})$  have the same value, and the external voltage source is time-independent, the time integration on the right hand side of Eq. (6) can be performed analytically, leading to the simpler solution Eq. (7). The integration kernel of Eq. (7) is defined in this case as follows:

$$\mathbf{K}^*(x, \xi, t) = \sum_{\substack{k=-(p-1) \\ k \neq 0}}^p \Gamma_k^*(x, \xi, t) \frac{\mathbf{b}_k \mathbf{b}_k^T}{\lambda_k} \quad (\text{B.4})$$

where the function  $\Gamma_k^*$  is obtained from the time integral of  $\Gamma_k$ :

$$\Gamma_k^*(x, \mathbf{x}, t) = \int_0^t \Gamma_k(x, \mathbf{x}, t') dt' \quad (\text{B.5})$$

The integration of Eq. (B.5) using the definition of Eq. (B.3) is straightforward:

$$\Gamma_k^*(x, \mathbf{x}, t) = \sum_{n=1}^{\infty} \frac{1 - e^{-t \left( \frac{r}{I_k} + \frac{n^2}{t_k} \right)}}{\frac{r}{I_k} + \frac{n^2}{t_k}} \sin\left(\frac{n\mathbf{p} x}{L}\right) \sin\left(\frac{n\mathbf{p} \mathbf{x}}{L}\right) \quad (\text{B.6})$$

where we have introduced the time constant  $t_k$  for the eigenmode  $k$ , defined as follows:

$$t_k = -I_k \mathbf{g}_k \left( \frac{L}{\mathbf{p}} \right)^2 \quad (\text{B.7})$$

As anticipated, a fast integration of the integral in Eq. (7) can be performed when the external voltage can be approximated as piecewise constant, defined by the series of vectors  $\mathbf{v}^{ext,m}$  relative to the space interval  $[x^m, x^{m+1}]$ , with  $m = 1, \dots, M$ . In this case the current distribution is computed using Eq. (9), where the kernel  $\mathbf{K}^{**}$  is obtained integrating Eq. (B.4) in space as follows:

$$\mathbf{K}^{**}(x, t; x^m, x^{m+1}) = \frac{1}{L} \int_{x^m}^{x^{m+1}} \mathbf{K}^*(x, \mathbf{x}, t) d\mathbf{x} = \sum_{\substack{k=-(p-1) \\ k \neq 0}}^p \mathbf{G}_k^{**}(x, t; x^m, x^{m+1}) \frac{\mathbf{b}_k \mathbf{b}_k^T}{\mathbf{I}_k} \quad (\text{B.8})$$

where we have defined the function  $\Gamma_k^{**}$  as follows:

$$\Gamma_k^{**}(x, t; x^m, x^{m+1}) = \frac{1}{L} \int_{x^m}^{x^{m+1}} \mathbf{G}_k^*(x, \mathbf{x}, t) d\mathbf{x} \quad (\text{B.9})$$

The result of the integral in Eq. (B.9) is:

$$\Gamma_k^{**}(x, t, x^m, x^{m+1}) = \sum_{n=1}^{\infty} \frac{1}{n\mathbf{p}} \frac{1 - e^{-t \left( \frac{r}{\mathbf{I}_k} + \frac{n^2}{\mathbf{t}_k} \right)}}{\left( \frac{r}{\mathbf{I}_k} + \frac{n^2}{\mathbf{t}_k} \right)} \sin\left(\frac{n\mathbf{p} x}{L}\right) \left[ \cos\left(\frac{n\mathbf{p} x^m}{L}\right) - \cos\left(\frac{n\mathbf{p} x^{m+1}}{L}\right) \right] \quad (\text{B.10})$$

In the form given above the analytical solution is expressed as an infinite series of trigonometric functions. The terms in the series are of oscillating nature, and although convergence to a finite solution is guaranteed, the summation must be extended on a large number of terms to achieve a good accuracy. For this reason it is more convenient to transform the above series as described in [16]. The resulting expressions are considerably more complex and are not reported here.

## Appendix C. Solution for a Two-strand Cable for Localised Voltage Excitation

In this section we show how to specialize the general analytic solution to the case of a two-strand cable. The source term is a localised longitudinal voltage, as e.g. due to a transposition error for a cable subjected to a change of the external magnetic field. This case has been already studied extensively in [11]. In order to achieve comparable results to those reported in [11], we start from the same hypotheses:

- zero total operating current  $i_{op}(t) = 0$ ;
- zero longitudinal resistance  $r = 0$ ;
- uniform longitudinal conductance per unit length  $g$ ;
- uniform self and mutual inductances per unit length,  $l$  and  $m$  respectively;
- external voltage excitation constant for a time  $t_1$  and limited to a short length  $d$  placed in the middle of the cable;
- cable length  $L$  multiple of an even number of twist pitches.

The external voltage per unit length is constant over the interval  $[x^1, x^2]$  and zero outside the interval, where the extremes of the interval are given by:

$$x^1 = \frac{L-d}{2} \quad (C.1)$$

$$x^2 = \frac{L+d}{2} \quad (C.2)$$

This case is obtained with our formalism taking a single space interval with constant voltage, i.e.  $M = 1$ . The voltage over this interval is  $\mathbf{v}^{ext,1}$ , corresponding to the single space interval defined by  $m = 1$ . We write the voltage vector in terms of the voltages on the strands as follows:

$$\mathbf{v}^{ext,1}(t) = \begin{bmatrix} v_1^{ext} \\ v_2^{ext} \end{bmatrix} U(t)U(t_1 - t) \quad (C.3)$$

where  $U(\mathbf{q})$  is the Heavyside function and  $v_1^{ext}$ ,  $v_2^{ext}$  are the voltages per unit length in the space interval (the index in the superscript has been dropped for simplicity) and for each of the two strands (indicated by the index in the subscript). The matrices  $\mathbf{l}$  and  $\mathbf{g}$  for a two-strand cable are the following:

$$\mathbf{l} = \begin{bmatrix} l & m \\ m & l \end{bmatrix} \quad (C.4)$$

$$\mathbf{g} = \begin{bmatrix} -g & g \\ g & -g \end{bmatrix} \quad (C.5)$$

and the eigenvalues of matrices  $\mathbf{l}$  and  $\mathbf{g}$  defined in Appendix A are given by:

$$\begin{cases} \mathbf{l}_0 = l + m \\ \mathbf{l}_1 = l - m \end{cases} \quad (\text{C.6})$$

$$\begin{cases} \mathbf{g}_0 = 0 \\ \mathbf{g}_1 = -2g \end{cases} \quad (\text{C.7}).$$

According to Eq. (B.7), the only time constant that is non-zero is  $\mathbf{t}_l$ , that we indicate simply with  $\mathbf{t}$ :

$$\mathbf{t} = -\mathbf{l}_1 \mathbf{g}_1 \left( \frac{L}{\mathbf{p}} \right)^2 = 2(l - m)g \left( \frac{L}{\mathbf{p}} \right)^2 \quad (\text{C.8})$$

that has the same definition as in [11]. The basis  $\mathbf{b}_k$ , with  $k = \{0, 1\}$ , is given by:

$$\mathbf{b}_0^T = \frac{1}{\sqrt{2}} [1 \quad 1] \quad (\text{C.9})$$

$$\mathbf{b}_1^T = \frac{1}{\sqrt{2}} [1 \quad -1] \quad (\text{C.10})$$

As the external voltage is a function of time, the general solution in this case is obtained from Eq. (6) that in the case of zero initial and total cable current can be simplified as follows:

$$\mathbf{i}(x, t) = \frac{2}{L} \int_0^L dx \int_0^t dq \mathbf{K}(x, \mathbf{x}, t - q) \mathbf{v}^{ext,1}(\mathbf{x}, q) \quad (\text{C.11}).$$

Equation (C.11) can be integrated in time using the definition of Eq. (C.3). For  $t \leq t_1$  the time integral of Eq. (C.11) leads to the same solution given by Eq. (9) where we take  $i_{op}(t)=0$  and the sum over the constant voltage intervals in space extends over a single interval,  $M=1$ , or:

$$\mathbf{i}(x, t) = 2\mathbf{K}^{**}(x, t; x^1, x^2) \mathbf{v}^{ext,1} \quad (\text{C.12}).$$

Substituting the definition of  $\mathbf{K}^{**}$  from Eq. (B.8), recalling that in this case  $p = 1$  so that the sum in Eq. (B.8) has a single term, and expanding the vector products, we obtain:

$$\mathbf{i}(x, t) = \frac{1}{l - m} \Gamma_1^{**}(x, t, x^1, x^2) \begin{bmatrix} v_1^{ext} - v_2^{ext} \\ v_2^{ext} - v_1^{ext} \end{bmatrix} \quad (\text{C.13}).$$



The definition of the function  $\Gamma_1^{**}$  is given in Eq. (B.10) where we take  $r = 0$ . Substituting in Eq. (C.13) we obtain:

$$\mathbf{i}(x, t) = \frac{1}{l-m} \sum_{n=1}^{\infty} \left\{ \frac{1}{n\mathbf{p}} \frac{\mathbf{t}}{n^2} \left( 1 - e^{-\frac{n^2}{\mathbf{t}}} \right) \sin\left(\frac{n\mathbf{p} x}{L}\right) \left[ \cos\left(\frac{n\mathbf{p} x^1}{L}\right) - \cos\left(\frac{n\mathbf{p} x^2}{L}\right) \right] \right\} \begin{bmatrix} v_1^{ext} - v_2^{ext} \\ v_2^{ext} - v_1^{ext} \end{bmatrix} \quad (\text{C.14}).$$

To show that Eq. (C.14) leads to the result obtained in [11] we introduce the following groups of parameters:

$$\mathbf{a} = \mathbf{p} \frac{L-d}{2L} \quad (\text{C.15}).$$

$$\mathbf{t}_n = \frac{\mathbf{t}}{n^2} \quad (\text{C.16}).$$

$$w = \frac{L-d}{2} \quad (\text{C.17}).$$

$$I_1 = \frac{w}{2} \mathbf{d}g (v_1^{ext} - v_2^{ext}) \quad (\text{C.18})$$

and we make the additional assumption that  $\delta \ll L$ . In this case we have that [16]:

$$\cos\left(\frac{n\mathbf{p}(L-d)}{2L}\right) - \cos\left(\frac{n\mathbf{p}(L+d)}{2L}\right) \cong \begin{cases} \frac{n\mathbf{p}d}{L} \sin(n\mathbf{a}) & \text{for } n \text{ odd} \\ 0 & \text{for } n \text{ even} \end{cases} \quad (\text{C.19}).$$

Using the above definitions and results, and after some manipulations, we can rewrite Eq. (C.14) in the following form:

$$\mathbf{i}(x, t) = \frac{4}{\mathbf{p}\mathbf{a}} I_1 \left\{ \sum_{\substack{n=1 \\ n \text{ odd}}}^{\infty} \frac{1}{n^2} \left( 1 - e^{-t/t_n} \right) \sin\left(\frac{n\mathbf{a} x}{w}\right) \sin(n\mathbf{a}) \right\} \begin{bmatrix} 1 \\ -1 \end{bmatrix} \quad (\text{C.20}).$$

The current in the two strands has the same amplitude but opposite sign. The current in the first strand is then simply given by:

$$i_1(x, t) = \frac{4}{\mathbf{p}\mathbf{a}} I_1 \sum_{\substack{n=1 \\ n \text{ odd}}}^{\infty} \frac{1}{n^2} \left( 1 - e^{-t/t_n} \right) \sin\left(\frac{n\mathbf{a} x}{w}\right) \sin(n\mathbf{a}) \quad (\text{C.21})$$

which is identical to the result of [11] that we wished to achieve. After the voltage pulse, i.e. for  $t > t_1$ , the solution for the current decay can be obtained from Eq. (6) decomposing the time integral as follows:

$$\mathbf{i}(x, t) = \frac{2}{L} \int_0^L d\mathbf{x} \int_0^{t_1} d\mathbf{q} \mathbf{K}(x, \mathbf{x}, t - \mathbf{q}) \mathbf{v}^{ext,1}(\mathbf{x}, \mathbf{q}) + \frac{2}{L} \int_0^L d\mathbf{x} \int_{t_1}^t d\mathbf{q} \mathbf{K}(x, \mathbf{x}, t - \mathbf{q}) \mathbf{v}^{ext,1}(\mathbf{x}, \mathbf{q}) \quad (\text{C.22})$$

By definition  $\mathbf{v}^{ext,1}(\mathbf{x}, \mathbf{q})$  is zero for  $t > t_1$ , so that the second integral on the right hand side of Eq. (C.22) disappears. Using now the change of variable  $\mathbf{q}' = t - \mathbf{q}$  we have that:

$$\mathbf{i}(x, t) = \frac{2}{L} \int_0^L d\mathbf{x} \int_{t-t_1}^t d\mathbf{q}' \mathbf{K}(x, \mathbf{x}, \mathbf{q}') \mathbf{v}^{ext,1}(\mathbf{x}, \mathbf{q}') \quad (\text{C.23}).$$

where now  $\mathbf{v}^{ext,1}(\mathbf{x}, \mathbf{q}')$  is constant for  $t - t_1 \leq \mathbf{q}' \leq t$ . The double integral in Eq. (C.23) leads then to the same primitives already defined for the general solution, and in particular:

$$\mathbf{i}(x, t) = 2\mathbf{K} ** (x, t; x^1, x^2) \mathbf{v}^{ext,1} - 2\mathbf{K} ** (x, t - t_1; x^1, x^2) \mathbf{v}^{ext,1} \quad (\text{C.24}).$$

Equation (C.24) can be transformed as outlined above, leading to:

$$\begin{aligned} \mathbf{i}(x, t) &= \frac{4}{\mathbf{p}\mathbf{a}} I_1 \left\{ \sum_{\substack{n=1 \\ n \text{ odd}}}^{\infty} \frac{1}{n^2} (e^{-t/t_n} - e^{-(t-t_1)/t_n}) \sin\left(\frac{n\mathbf{a}x}{w}\right) \sin(n\mathbf{a}) \right\} \begin{bmatrix} 1 \\ -1 \end{bmatrix} = \\ &= \frac{4}{\mathbf{p}\mathbf{a}} I_1 \left\{ \sum_{\substack{n=1 \\ n \text{ odd}}}^{\infty} \frac{1}{n^2} e^{-(t-t_1)/t_n} (1 - e^{-t_1/t_n}) \sin\left(\frac{n\mathbf{a}x}{w}\right) \sin(n\mathbf{a}) \right\} \begin{bmatrix} 1 \\ -1 \end{bmatrix} \end{aligned} \quad (\text{C.25})$$

that corresponds to the results found in [11], and namely that each component of order  $n$  has a free decay with the time constant  $t_n$  from the current reached at time  $t_1$ .

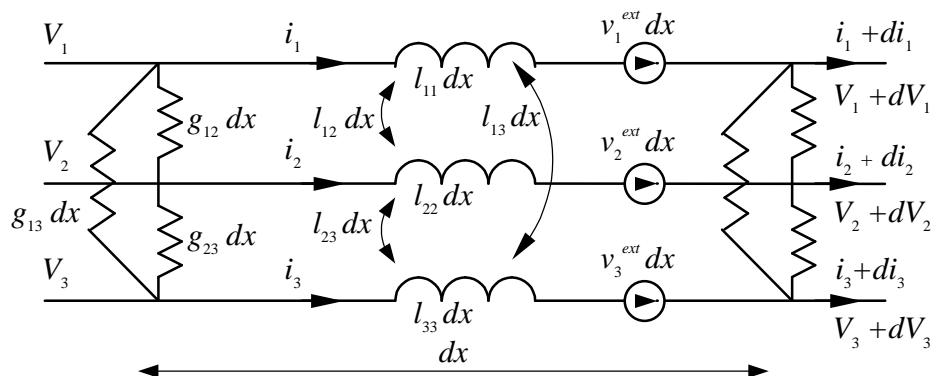

Figure 1. Distributed parameters circuit model of the elemental mesh of cable used to describe current distribution in multistrand superconducting cables.

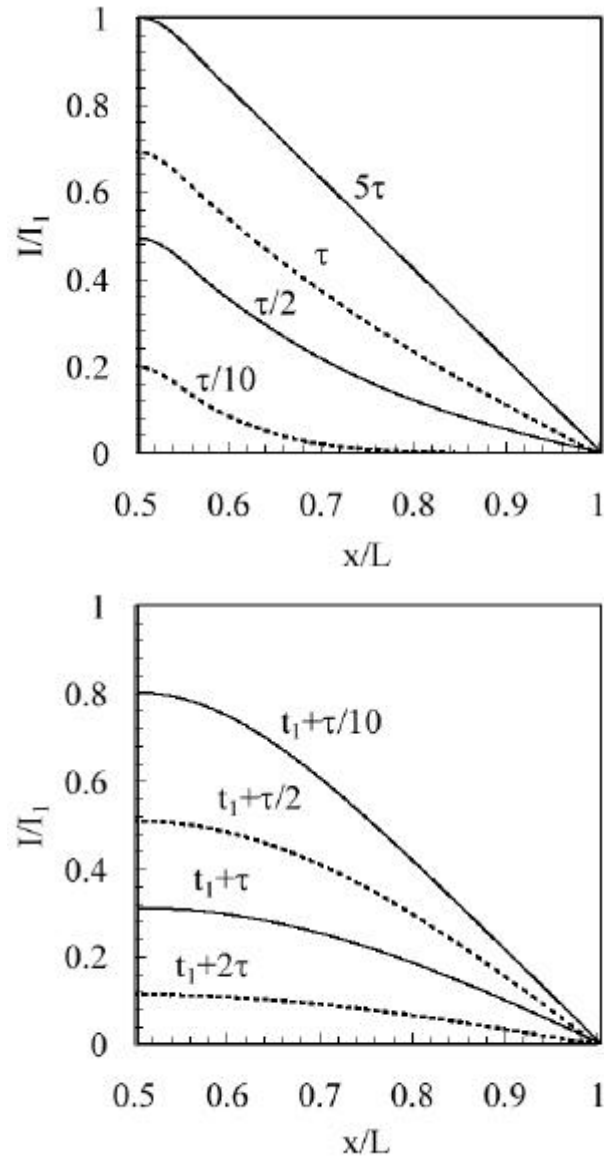

Figure 2. Evolution of the current in the first strand of a two-strand cable with the parameters discussed in the text and subjected to a localised longitudinal voltage source. The current is normalised to the maximum current  $I_1$ . The localised voltage source acts in the center of the cable for a time  $t_1$  equal to  $5\tau$ , and is equal to zero after this time. The left plot reports the current rise under the external voltage for  $t < t_1$ , while the right plot shows the current decay for  $t > t_1$ .

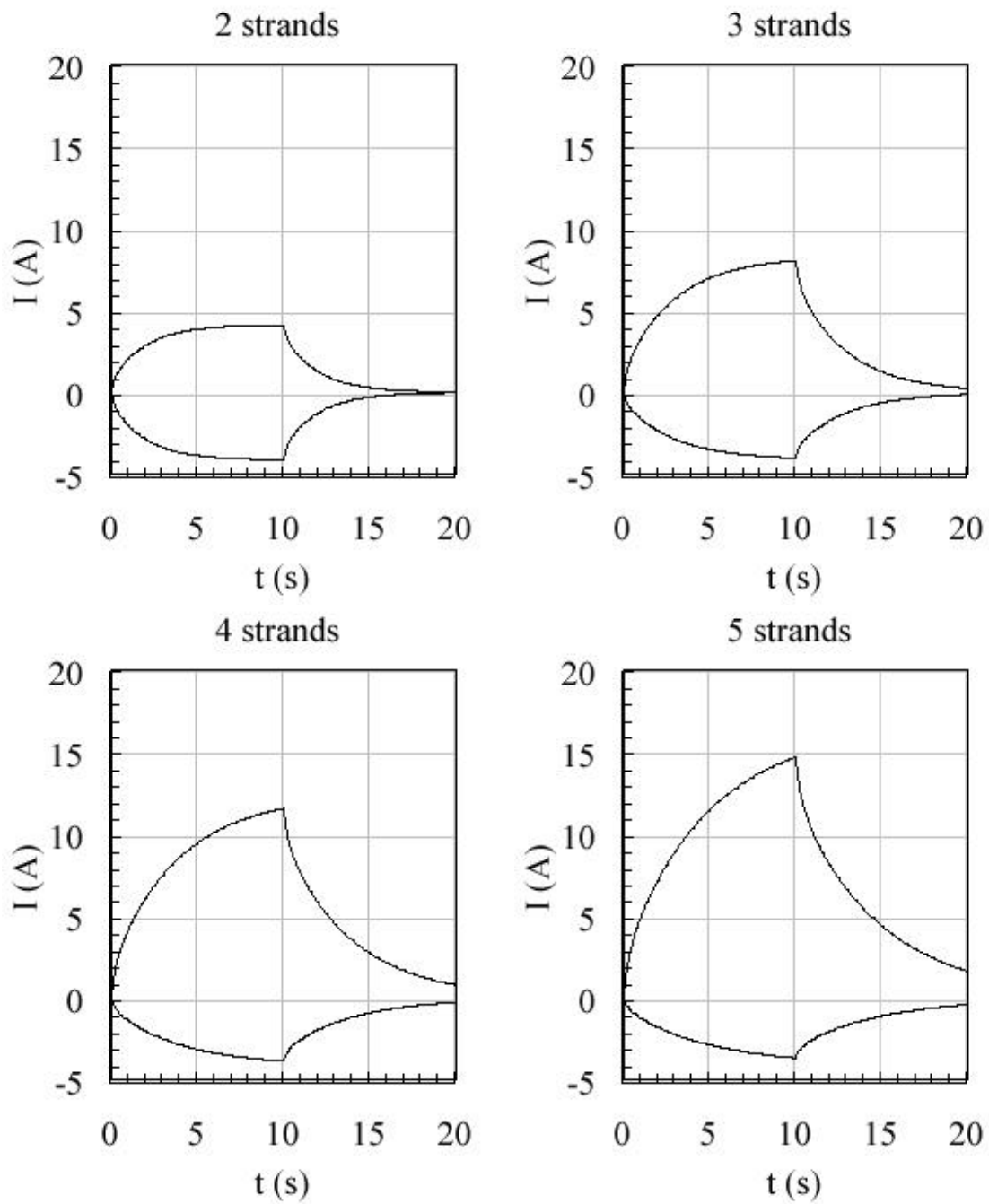

Figure 3. Evolution of the strand currents in the center of cables made of few strands with the same conditions considered in Fig. 2. The current in the first strand is positive, while the currents in all other strands are negative and equal to each other.

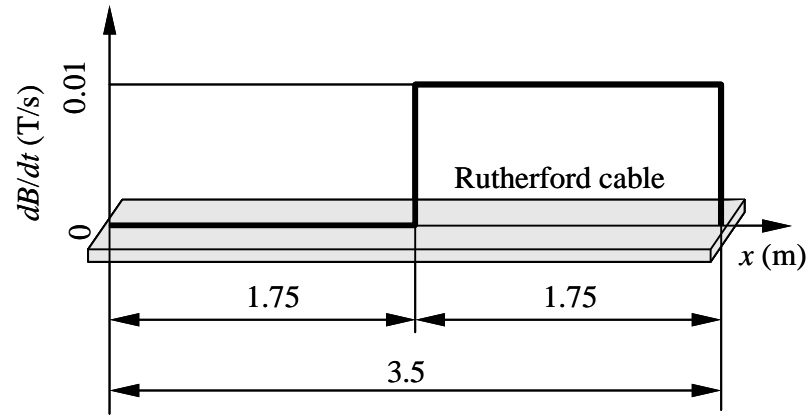

Figure 4. Field derivative along the Rutherford cable, producing the voltage source used for the numerical simulation of Figs. 5 and 6.

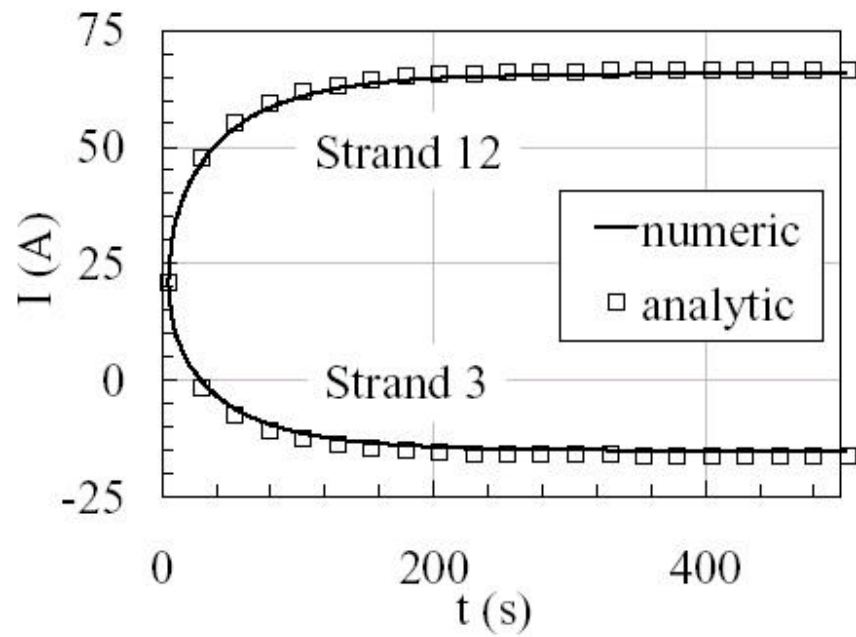

Figure 5. Comparison between analytical and numerical solution of the time dependent strand currents induced in a 16-strand Rutherford cable exposed to a localized change in the applied magnetic flux density perpendicular to the broad face of the cable. The current in the center of the cable is plotted for two arbitrarily selected strands.

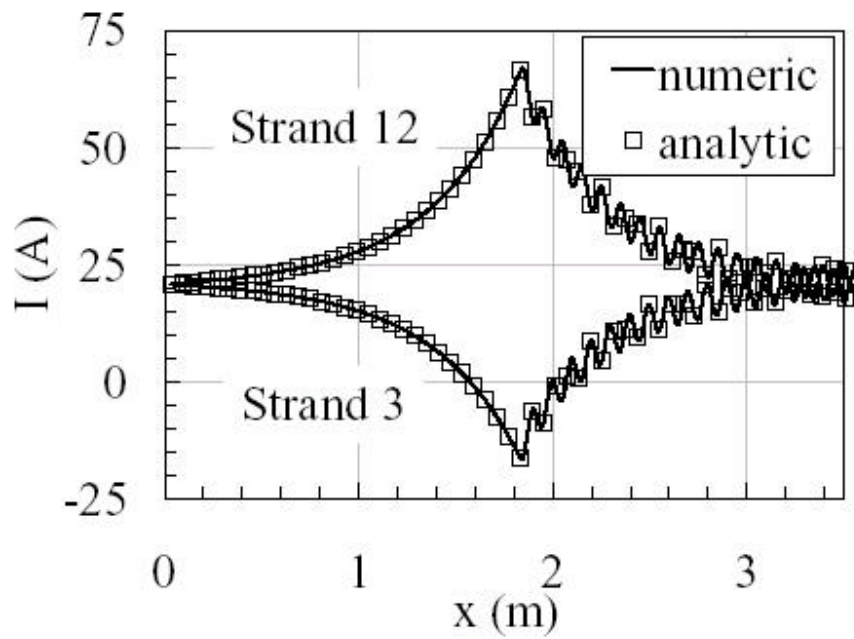

Figure 6. Comparison between analytical and numerical solution of the regime solution for the strand currents in a 16-strand Rutherford cable subjected to a localized change in the applied magnetic flux density perpendicular to the broad face of the cable.